

Stoewer Kfz.2, SS division Totenkopf, Eastern Front 1942

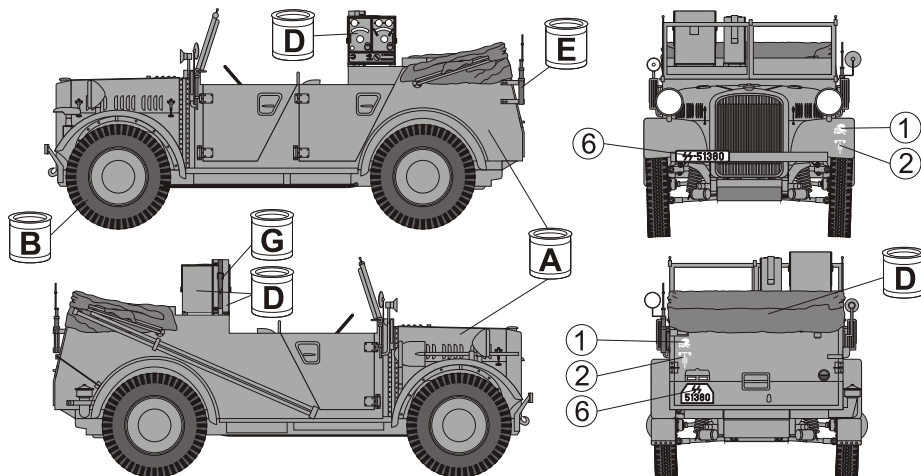

Stoewer Kfz.2, Wermacht, Eastern Front 1943

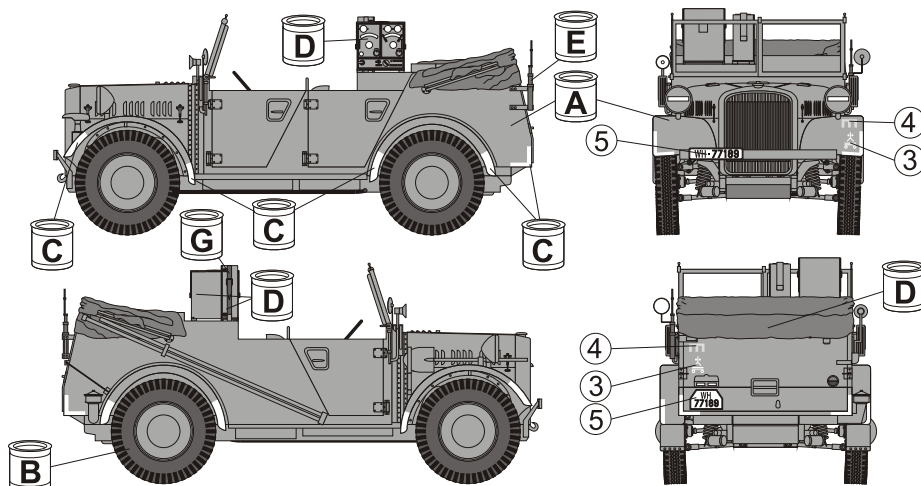

Při stavbě postupujte podle instruktážního obrázku

Follow the instruction drawing the assembly.

Upozornění: Během opravování může vznikat prach, který může dráždit dýchací cesty. Použijte ochranu očí při odstřihování kovových dílů.

Notice: Machining can produce dust which can be irritating to the respiratory tract. Metal parts should be cut off using protection eyesight.

Plus Model s.r.o.
Jižní 56, 370 10 České Budějovice
Czech Republic
<http://www.plusmodel.cz>
e-mail: plusmodel@plusmodel.cz

Kupujte přímo na www.plusmodel.cz
Buy directly from www.plusmodel.cz

205

plusmodel

Scale
1/35



STÖEWER Kfz.2

Historie

Univerzální lehký terénní automobil, vyráběný firmou Stoewer v letech 1936 - 1943. Na výrobě se v letech 1937 - 1940 podílely také firmy BMW a Hanomag. Všechny vozy se v drobnostech lišily (firma BMW například používala šestiválcový motor).

Kromě starších Stoewer R180 Special a typu 40 z let 1940-43 měla všechna vozidla na přání řízení všech čtyř kol. Typy karoserií zahrnovaly Kfz.1 (čtyřmístná), Kfz.2 (spojovací), Kfz.2/40 (údržba a opravy) a Kfz.3 (lehké průzkumné vozidlo). Všechny typy byly používány na všech frontách II. světové války.

Technická data:

Motor - čtyřválcový kapalinou chlazený Stower AW2 OHV objem - 1997 cm

Výkon - 37 kW (50k)

Spojka - suchá kotoučová

Převodovka - 5 stupňů vpřed, 1 vzad, přídatná jednostupňová

převodovka s mezinápravovým diferenciálem

Brzdy - mechanické

Rozvor - 2400 mm

Délka - 3900 mm

Šířka - 1690 mm

Výška - 1900 mm

Hmotnost - 1780 kg

History

Light Universal Off-road car was built by Stoewer company in 1933 - 1943 y. There was produced also by BMW a Hanomag companies. There were some differences between cars (e.g. cars from BMW company had six cylinder engine).

Except Stoewer R180 Special and type 40, all vehicles had all wheels controllable. There were used four variants of vehicle body: Kfz.1 (four man), Kfz.2 (liaison), Kfz.2/40 (repair) and Kfz.3 (light scout car). All variants were used in all theatres of WW II. There were built about 13 000 vehicles, few of them survived.

Technical specifications:

Engine - Four cylinder Stower AW2 OHV, 1997 ccm, 37 kW (50 HP)

Gear box - Five forward, one reverse plus one auxiliary box

Clutch - Disc, dry

Brakes - Mechanical

Fuel capacity - 60 L gasoline

Wheel base - 2400 mm

Length - 3900 mm

Width - 1690 mm

Height - 1900 mm

Weight - 1780 kg

Kusovník a značení dílů - Numbering of parts

Resinové díly - Resin parts

Odstranit
Remove

Clear parts

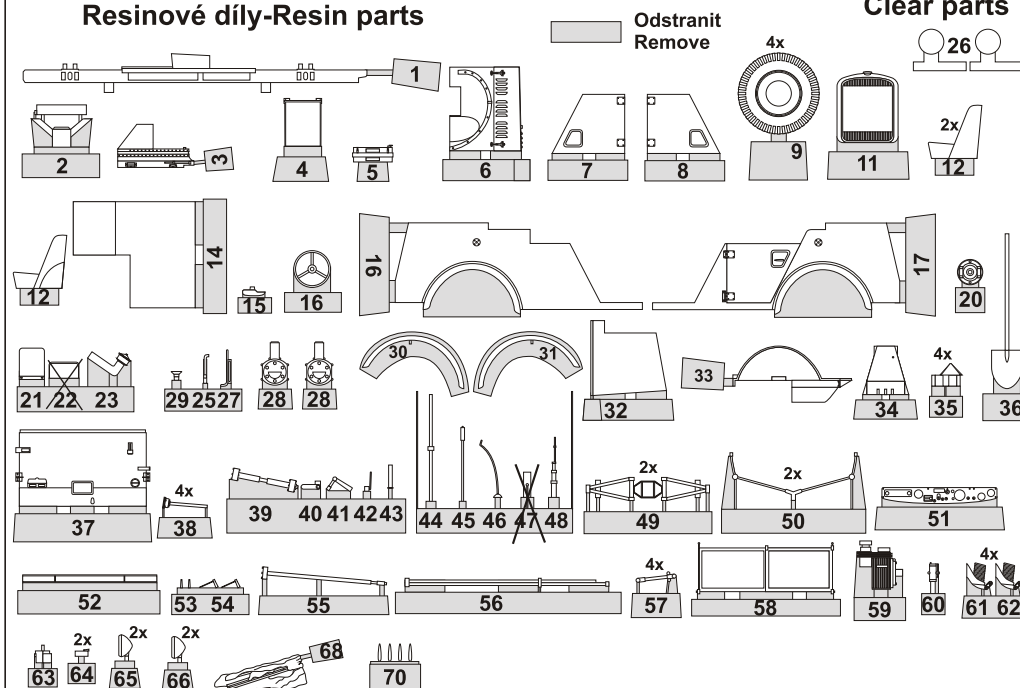

Kovové díly-Metal parts

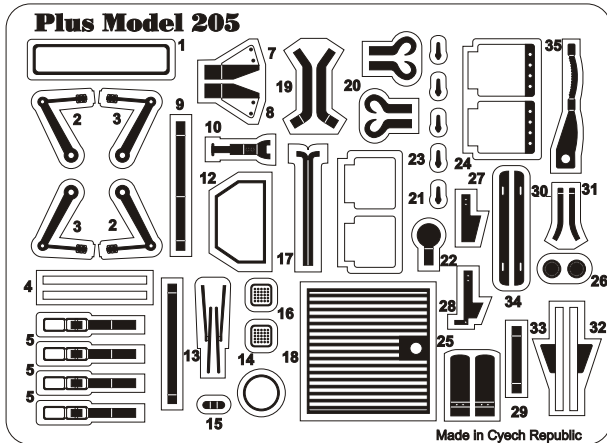

M1

M2

Obtisky-Decals

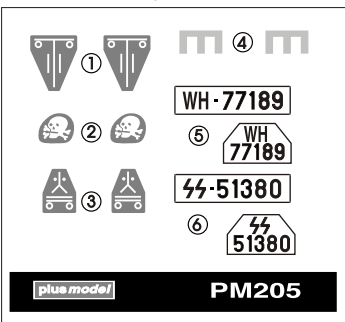

Fólie-Plastic film

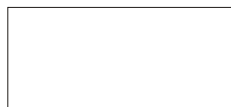

Barvy- Colours

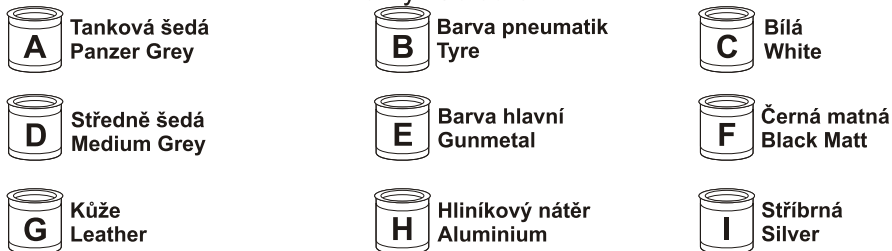

Symboly - Symbols

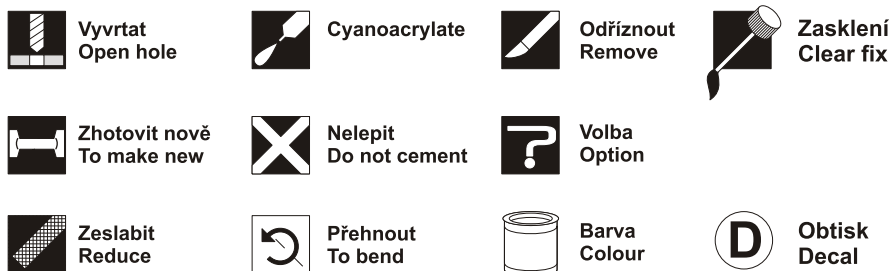

Stavební postup - Assembly instructions

22

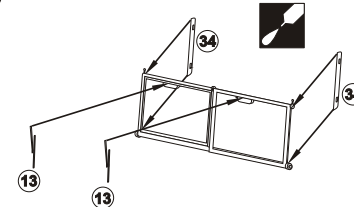
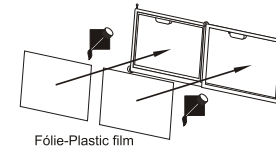
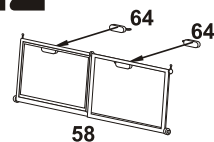

23

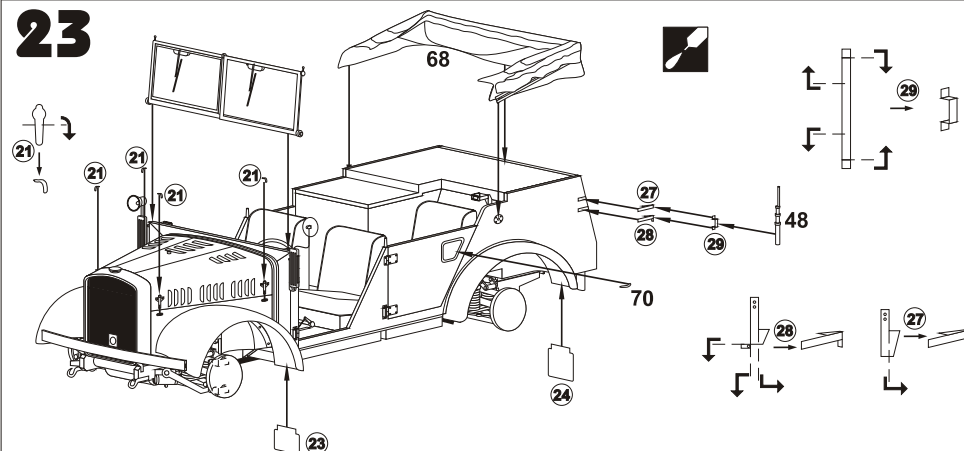

24

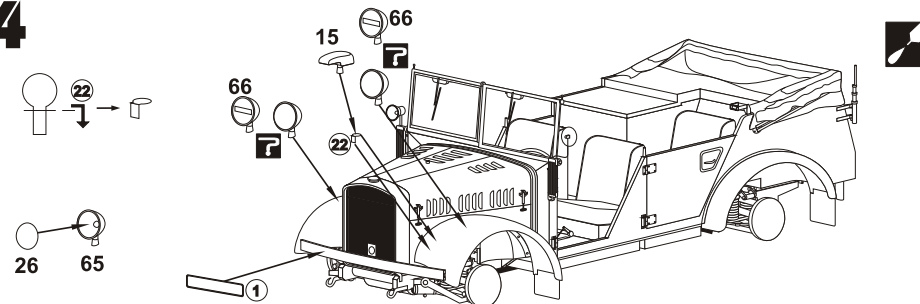

25

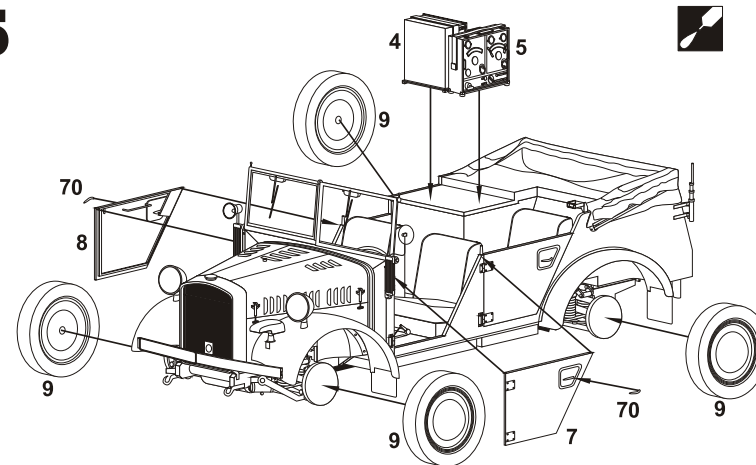

Stavební postup - Assembly instructions

19

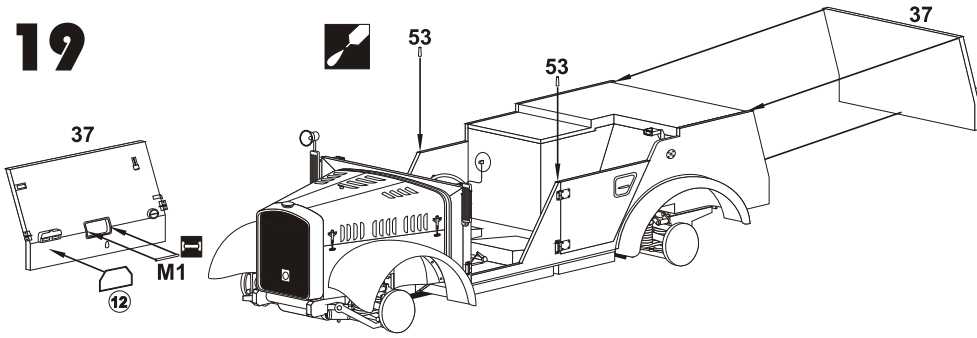

20

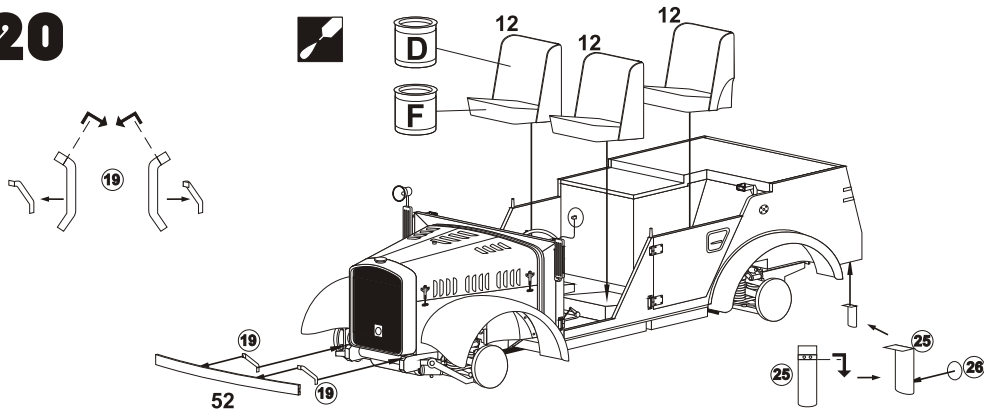

21

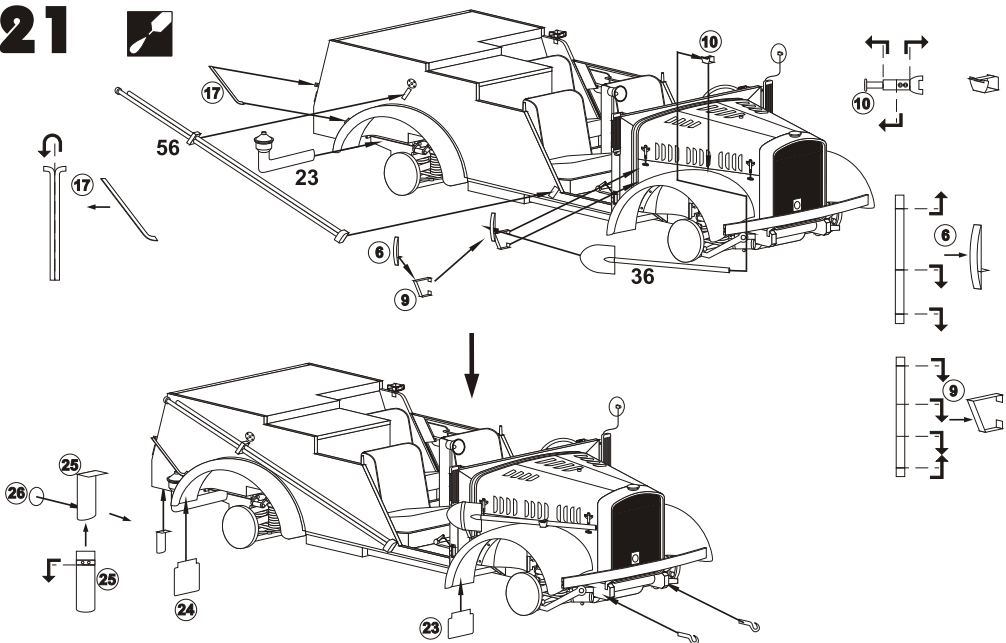

Stavební postup - Assembly instructions

1

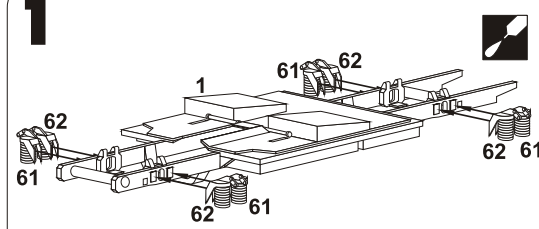

2

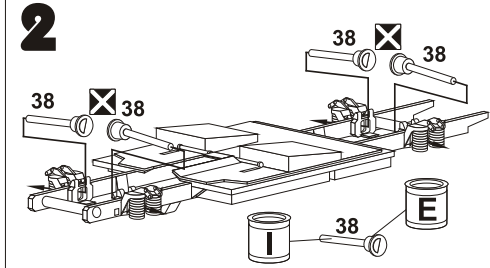

3

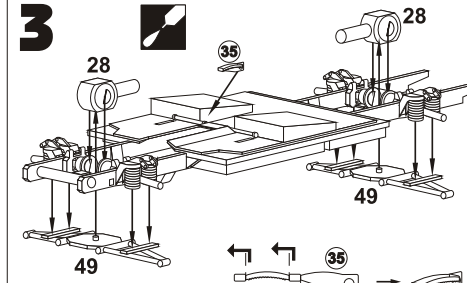

4

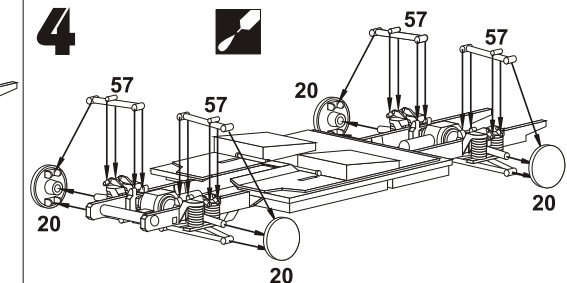

5

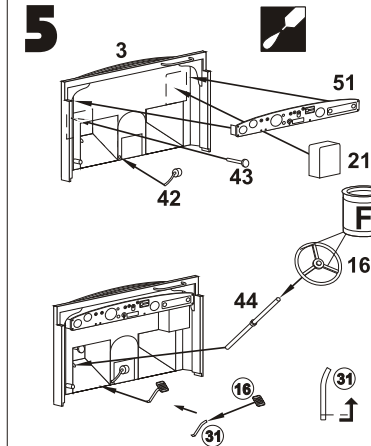

6

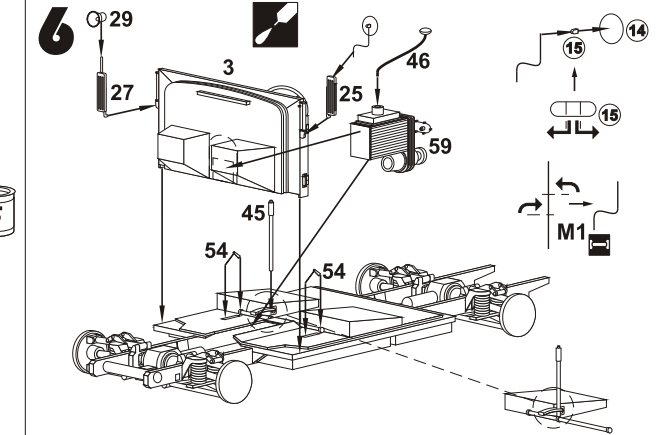

7

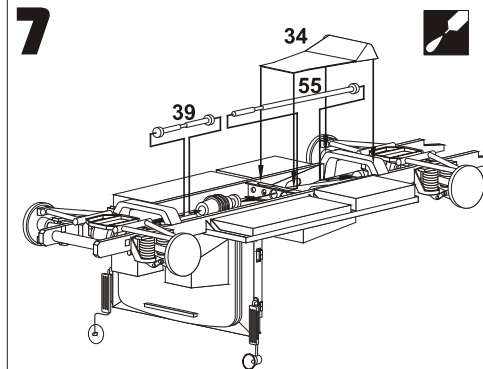

8

